

A	B	C	D	E	F	G	H	COLUMNS	POWER
3'-5 1/2"	---	1'-8"	3'-0"	---	---	5'-0"	---	---	REFERENCE 01-2000-01-1

DIMENSIONS

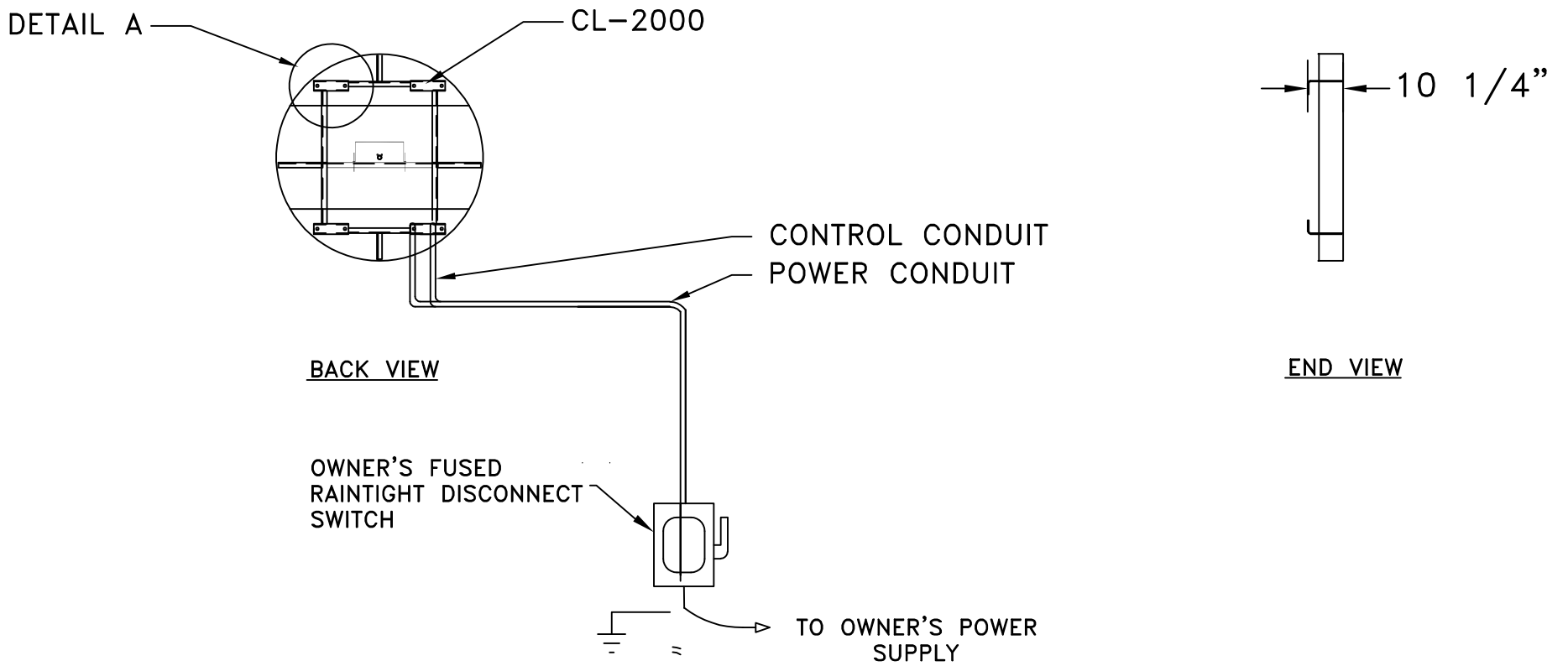

COLUMNS AND FOOTINGS SHOWN HERE, PROVIDED BY OTHERS, ARE SIZED TO COMPLY WITH IBC 2006 90 MPH EXPOSURE B REQUIREMENTS. THE MANUFACTURED PRODUCT EXCEEDS THE REQUIREMENTS OF IBC 2006 90 MPH EXPOSURE B AS MOUNTED IN THIS DRAWING. SOIL STRENGTH WITH ALLOWABLE STRESSES OF 100 psf PER FT BELOW NATURAL GRADE. DESIGN SHOULD BE ALTERED FOR DIFFERENT SOIL CONDITIONS, CLEARANCE, OR LOCAL CODES. FAIR-PLAY ASSUMES NO RESPONSIBILITIES FOR INSTALLATIONS DONE BY OTHERS.

CONTROL CABLES- SUGGEST 3/4" CONDUIT BE USED FOR BURIED CABLE IN AREAS WHERE IT MAY BE SUBJECT TO MECHANICAL DAMAGE. POWER WIRES SHOULD BE ROUTED IN SEPARATE CONDUIT FROM CONTROL CABLE.

INSTALLATION DRAWING SHOULD BE REVIEWED BY A LICENSED PROFESSIONAL ENGINEER IN YOUR AREA PRIOR TO CONSTRUCTION.

REFERENCE 01-0500-01 FOR INSTALLATION NOTES.

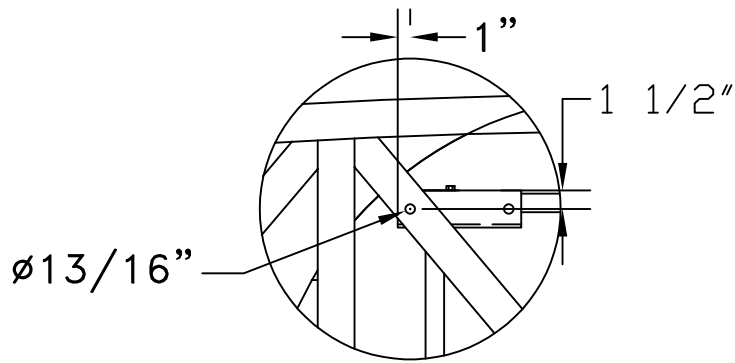

DETAIL A
"J" BRACKET
1/4" PLATE STEEL

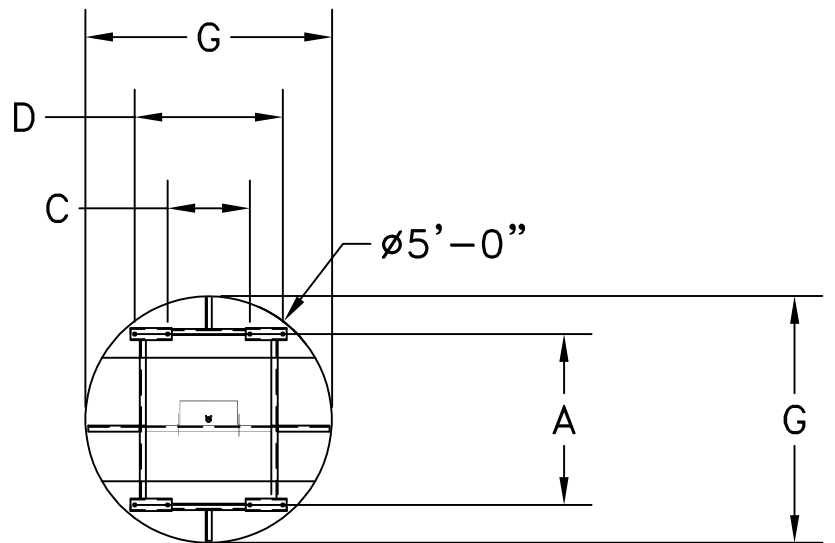

HANGER BRACKET DETAIL
BACK VIEW

CUSTOMER APPROVAL:	MY SIGNATURE BELOW SIGNIFIES MY APPROVAL TO PROCEED WITH THE DESIGN WORK SPECIFIED HEREIN AND ACKNOWLEDGEMENT THAT I HAVE RECEIVED AND READ THE INSTALLATION SPECIFICATIONS CONTAINED IN FAIR-PLAY DOCUMENT NO. 01-0500-01. CONSULT YOUR FAIR-PLAY SALES ASSOCIATE IF YOU SHOULD HAVE ANY QUESTIONS OR REQUIRE ANY CHANGES TO THIS DOCUMENT.		
PROJECT:	SIGNATURE:	DATE:	
REFERENCE #:	PRINT NAME:		

FAIR-PLAY 6110 AVIATOR DRIVE HAZELWOOD, MO 63042	THIS DOCUMENT CONTAINS FAIR-PLAY PROPRIETARY INFORMATION. ANY DISCLOSURE, USE OR DUPLICATION OF THE DOCUMENT OR OF ANY INFORMATION CONTAINED THEREIN FOR OTHER THAN THE SPECIFIC PURPOSE FOR WHICH IT WAS DISCLOSED IS EXPRESSLY PROHIBITED, EXCEPT AS MAY BE OTHERWISE AGREED TO IN WRITING. COPYRIGHT 2022.		
	TITLE	DRAWN BY	MODEL
	INSTALLATION FOR CL-2000	BEW	B CL-2000
		DATE 07-30-13	DWG. NO. 01-2000-01-2
	SCALE 1/4"=1'-0"		

A	UPDATED TITLE BLOCK FORMAT	11-30-22	BEW
OR	ORIGINAL RELEASE	07-30-13	BEW
REV.#	CHANGE	DATE	BY