

A	B	C	D	E	F	G	H	COLUMNS	POWER
4'-6"	2'-3"	3'-9 1/2"	1 1/4"	2'-6"	5'-0"	4'-0"	9'-0"	W8 X 13	REFERENCE 01-8109-01-1

DIMENSIONS

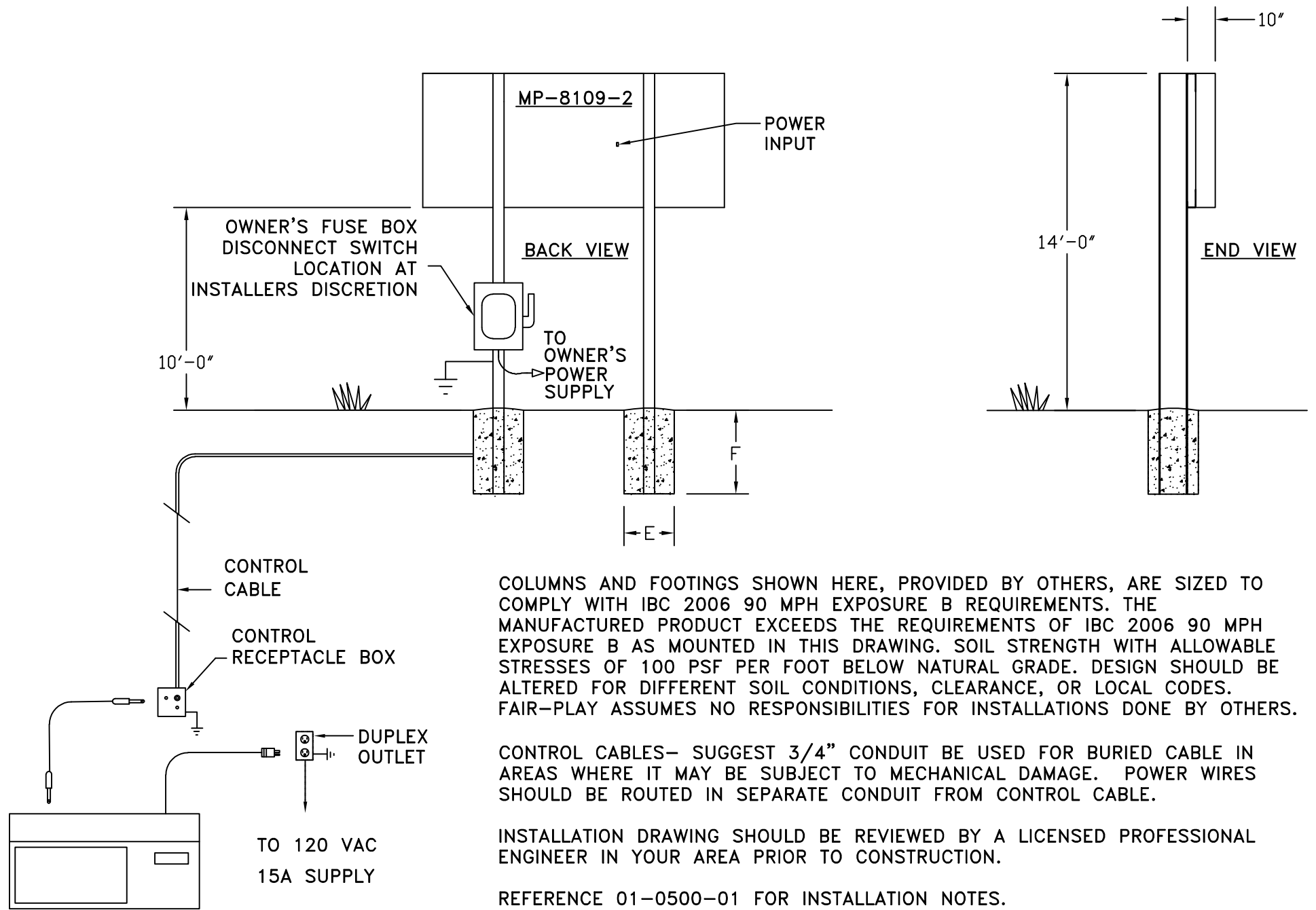

SCBD CONTROL

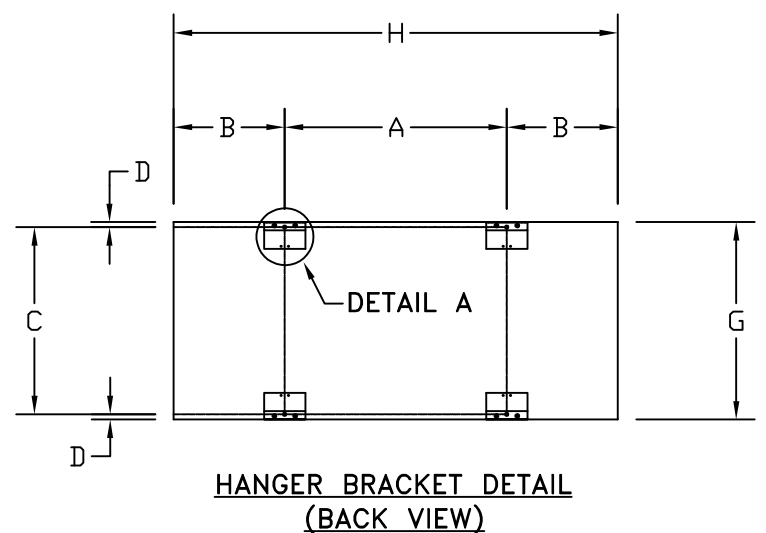
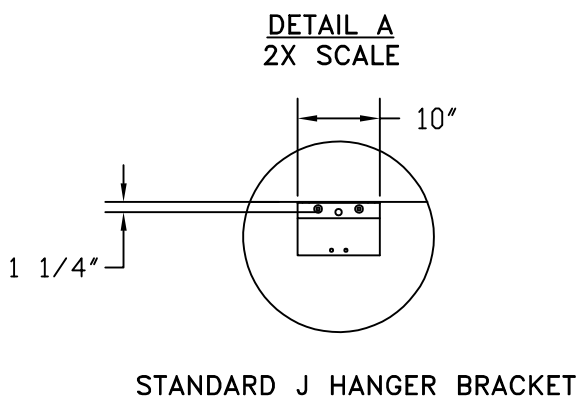

CUSTOMER APPROVAL:	MY SIGNATURE BELOW SIGNIFIES MY APPROVAL TO PROCEED WITH THE DESIGN WORK SPECIFIED HEREIN AND ACKNOWLEDGEMENT THAT I HAVE RECEIVED AND READ THE INSTALLATION SPECIFICATIONS CONTAINED IN FAIR-PLAY DOCUMENT NO. 01-0500-01. CONSULT YOUR FAIR-PLAY SALES ASSOCIATE IF YOU SHOULD HAVE ANY QUESTIONS OR REQUIRE ANY CHANGES TO THIS DOCUMENT.	
PROJECT:	SIGNATURE:	DATE:
REFERENCE #:	PRINT NAME:	

FAIR-PLAY 6110 AVIATOR DRIVE HAZELWOOD, MO 63042	THIS DOCUMENT CONTAINS FAIR-PLAY PROPRIETARY INFORMATION. ANY DISCLOSURE, USE OR DUPLICATION OF THE DOCUMENT OR OF ANY INFORMATION CONTAINED THEREIN FOR OTHER THAN THE SPECIFIC PURPOSE FOR WHICH IT WAS DISCLOSED IS EXPRESSLY PROHIBITED, EXCEPT AS MAY BE OTHERWISE AGREED TO IN WRITING. COPYRIGHT 2022.	
	TITLE	MODEL
	INSTALLATION FOR MP-8109-2	B MP-8109-2
	DRAWN BY RMS DATE 03-11-10 SCALE 1/4"=1'-0"	DWG. NO. 01-8109-01-2

REV.#	DESCRIPTION	DATE	BY
A	UPDATED TITLE BLOCK FORMAT	08-18-22	BEW
OR	ORIGINAL RELEASE	03-11-10	RMS
	CHANGE		