

***Fair-Play***

---

**A TRANS·LUX® COMPANY**

**LED BAR DIGIT WRESTLING SCOREBOARD  
INSTRUCTION MANUAL**

REVISION DATE: 11-07-08

PART#: 98-1400-01

# *Fair-Play*

---

**A TRANS·LUX<sup>®</sup> COMPANY**

## **SERVICE & CUSTOMER INFORMATION**

CUSTOMER MUST HAVE PART NUMBER WHEN ORDERING ITEMS THROUGH THE SERVICE DEPARTMENT.

IF FURTHER HELP IS NEEDED CONTACT A FAIR-PLAY SERVICE REP IN YOUR FAIR-PLAY DEALER ORGANIZATION OR PHONE THE FAIR-PLAY HELP DESK AT (800) 462-2716.

TO AID YOU IN YOUR DISCUSSIONS WITH SERVICE REPS, WE SUGGEST THAT YOU RECORD THE FOLLOWING:

MODEL NUMBER: \_\_\_\_\_

FAIR-PLAY SALES ORDER NUMBER: \_\_\_\_\_

(THIS NUMBER IS FOUND IN THE UPPER RIGHT HAND CORNER OF THE PACKING SLIP AND INVOICE.)

INSTALLATION DATE: \_\_\_\_\_

WARRANTY: A COPY OF THE **FIVE-YEAR LIMITED WARRANTY** IS ENCLOSED.

# FAIR-PLAY SCOREBOARDS

## INSTRUCTION DRAWING LIST

### **STANDARD LED BAR DIGIT WRESTLING** TABLE OF CONTENTS

DESCRIPTION	DRAWING NUMBER
PREFACE FOR WR-1400.....	98-1400-01-2
INSTALLATION FOR WR-1400-3S-4.....	01-0138-02-1
3-SIDED ASSEMBLY.....	32-1400-12
TYPICAL WIRING FOR WR-1400-3S-4.....	10-1400-04
TYPICAL WIRING FOR WR-1400-4 WITH SCORE OPTIONS.....	10-1400-05
TYPICAL WIRING FOR WR-1400-2S-4.....	10-1400-07
HANGER SPACING 1-SIDED.....	32-1400-13
ASSEMBLY FOR WR-1400-4 AND WR-1401-4.....	32-1400-15
ELECTRICAL HARNESS PARTS CHART FOR LED BAR MODELS.....	98-0021-03
CHART FOR SCOREBOARD DETAILS	
WARRANTY	

## **INTRODUCTION**

Your scoreboard is economical and professional looking, which is designed to meet the needs of high school and college level facilities. This instruction booklet will provide you with information to install and troubleshoot your scoreboard. If further assistance is needed, contact your local authorized Fair-Play Representative or contact the Fair-Play Service Department at 1-800-747-5305 or 1-800-462-2716.

## **INSTALLATION**

Your scoreboard requires 120 VAC, 60 Hz, 2-wire grounded power supply at the scoreboard and at the control location for model WR-1400. Reference installation for control cable

Fair-Play assumes no responsibilities for installations done by others.

The following items must be considered when installing your new scoreboard. Any technical questions should be directed towards a qualified technician.

1. The control data cable and power cables must be routed in separate conduit.  
**(Placing low voltage data cables with high voltage power cable will create a safety hazard and/or damage to your equipment.)**
2. Data cables may be paralleled from one scoreboard to the next. Ref. Appendix A of the MP-70 user guide for the correct procedure.
3. Connect the shield wire at one end only of the data cable.  
**(Connecting the shield at both ends may cause a ground loop, which could lead to erratic operation of the scoreboard.)**
4. The 4x4 data hook-up box provided with your system must be located within ten feet of the control operating location. A ten foot cable is provided, longer cables are available at an additional cost. Contact your local Fair-Play Representative or the Fair-Play Service Department if required.
5. Switch power off to the system when not in use. The control console should and placed in the storage closet to protect against damage.

## **SAFETY FEATURE**

Fair-Play incorporates the following safety feature on model WR-1400. A lit segment will travel between several digits when 120 VAC power remains connected to the scoreboard. This feature alerts persons who service the equipment that there is a potential danger of electrical shock if power is not disconnected.

If problems develop after the installation is complete, contact your Fair-Play representative or the Fair-Play Service Department.

# INSTALLATION

## WR-1400-3S-4

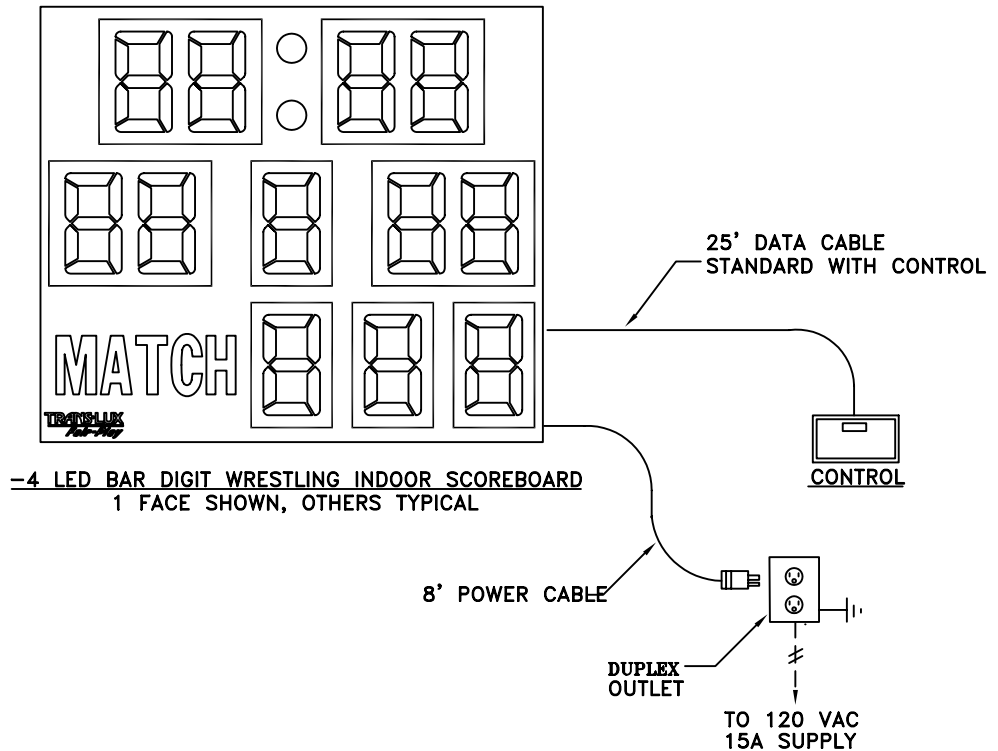

### WR-1400-3S-4

SIZE: 2'-6"L X 2'-2"H, PER FACE

POWER: 120 VAC, 60 Hz., 1-PHASE  
40 WATTS. (1 FACE)  
120 WATTS. (3 FACES)

120 VAC AT THE CONTROL LOCATION.

CONTROL CONSOLE: MP-70.

CONTROL CABLE: (1) TWO CONDUCTOR SHIELDED.

LAMPS: LED BAR.

OPTIONS: MODEL HH-70 CLOCK HAND SWITCH FOR SECOND OPERATOR.  
(CLOCK START/STOP & MANUAL HORN.)

MODEL HC-70 CLOCK HAND SWITCH FOR SECOND OPERATOR.  
(CLOCK START/STOP & CLOCK RESET.)

WEB ADDRESS  
FAIR-PLAY SCOREBOARDS  
FACTORY ADDRESS  
PHONE

fair-play.com  
PO BOX 1847  
1700 DELAWARE AVE.  
515-265-5305

DES MOINES, IOWA 50306-1847  
DES MOINES, IOWA 50317-2999

111903 BEW

01-0138-02-1

REV.#	CHANGE	DATE	BY
B	ADDED CONTROL AND POWER AND MODEL	1/12/04	NAP
A	CHANGED DIGIT COLORS	12-19-03	BEW

Parts List			
ITEM	QTY	PART NUMBER	DESCRIPTION
1	3	32-1400-11	CABINET ASSY, WR-1400
2	1	30-1400-15	3-SIDED SUPPORT
3	1	30-1400-14	SCOREBOARD BASE
4	3	30-1400-13	END ANGLES, 3 SIDED

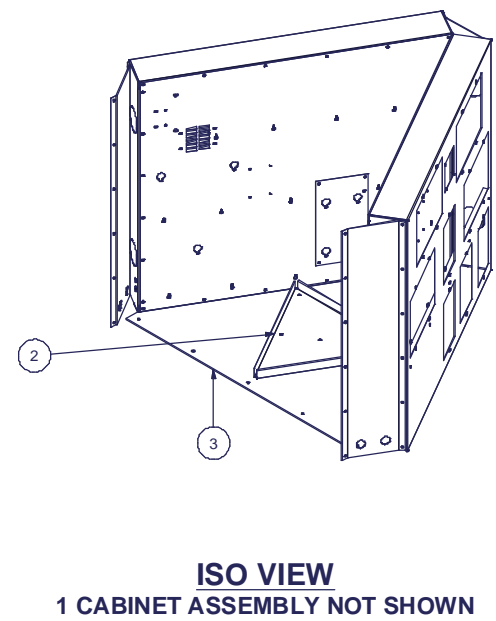
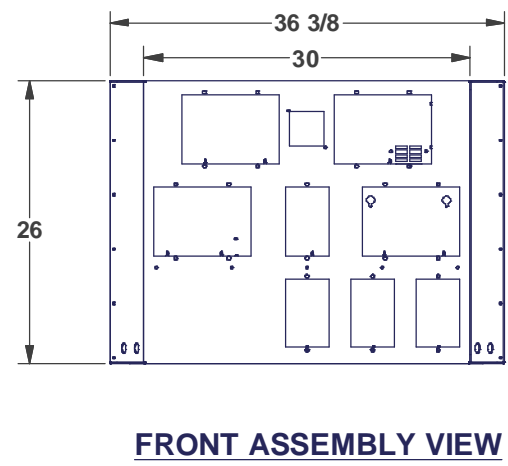
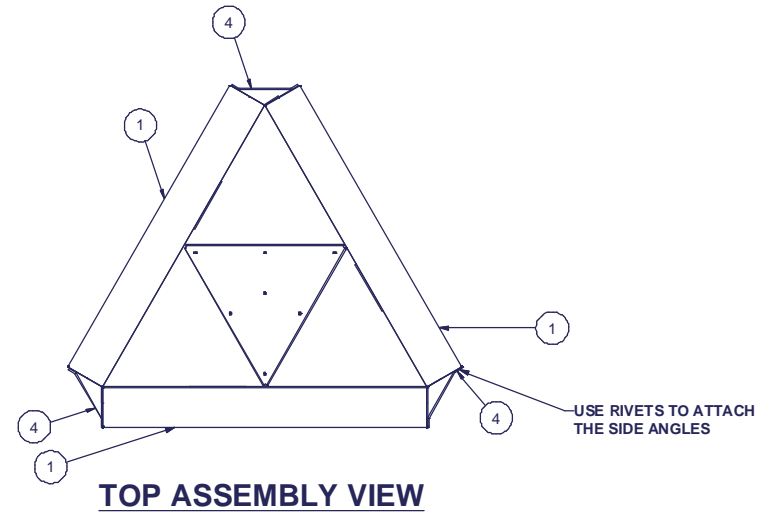

DRAWN Ldsbocker	12/31/2003	<b>TRANS-LUX</b>	THIS DOCUMENT CONTAINS TRANS-LUX PROPRIETARY INFORMATION. ANY DISCLOSURE, USE OR DUPLICATION OF THE DOCUMENT OR OF ANY INFORMATION CONTAINED THEREIN FOR OTHER THAN THE SPECIFIC PURPOSE FOR WHICH IT WAS DISCLOSED IS EXPRESSLY PROHIBITED, EXCEPT AS MAY BE OTHERWISE AGREED TO IN WRITING.	
CHECKED			TITLE	
QA		<b>3-SIDED, WR-1400</b>		
MFG				
APPROVED		SIZE	DWG NO	REV
		C	<b>32-1400-12</b>	
		SCALE	SHEET 1 OF 1	

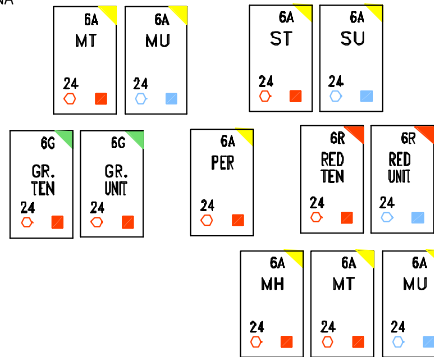
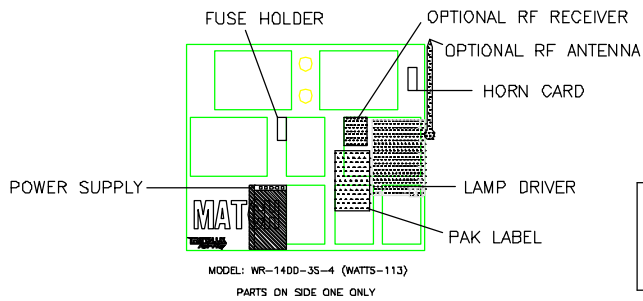

**ASSEMBLY NOTES:**

\*NYOGEL 760G REQUIRED AT LOCATIONS:  
K1A-K10A, K1B-K10B, K23, ON DRIVER LED2022  
ALL CONNECTIONS (HEADERS) ON THE DIGITS.

\*NYOGEL NOT REQUIRED AT LOCATIONS:  
K21, K22, K20, K28, & K24 ON DRIVER LED2022

\*POWER SUPPLY:  
VERIFY POWER SUPPLY IS SWITCHED TO 115VAC  
MEASURE VOLTAGE AT POWER SUPPLY=15 VOLTS DC

\*HIPOT TEST REQUIREMENTS:  
1.5 KILOVOLTS FOR 1 SECOND

\*CONTINUITY CHECK BETWEEN CABINET AND GROUND.

\*ONE HARNESS WILL CONNECT ALL THREE SIDES TO  
ONE DRIVER SEE 16-0001-02 FOR CABLES.

\*POWER CORD AND DATA WILL HAVE TO BE PLACED  
AT THE CORNER DUE TO CLOSED BOTTOM.

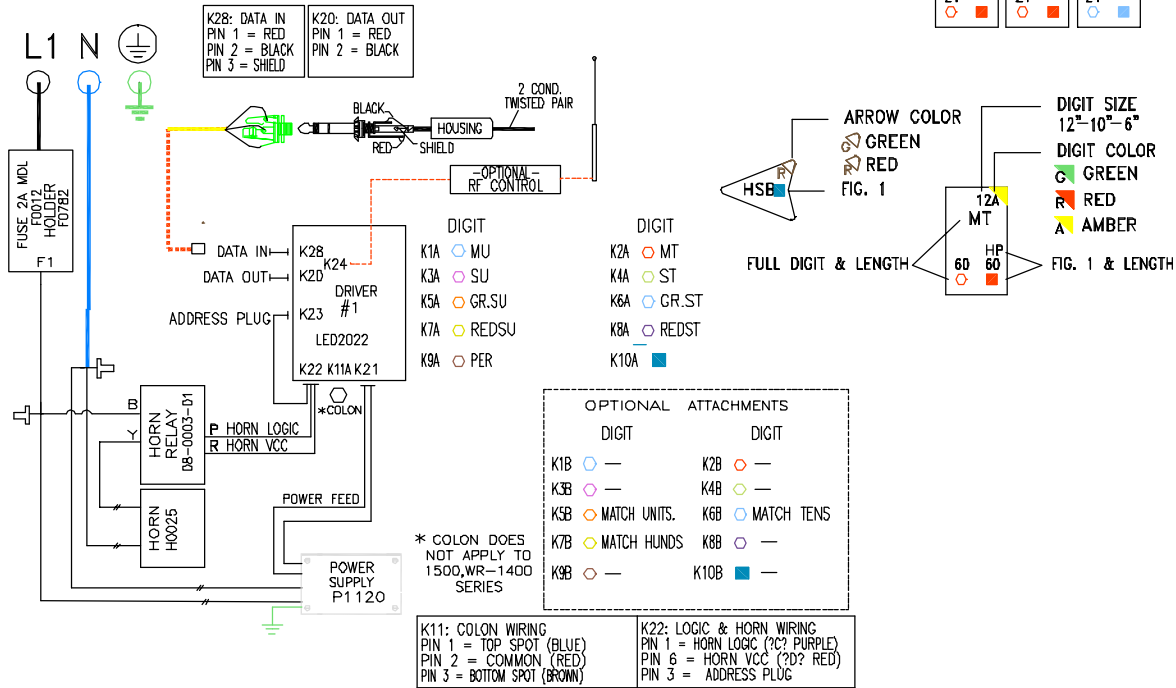

**TRANS·LUX**

THIS DOCUMENT CONTAINS TRANS-LUX PROPRIETARY INFORMATION. ANY DISCLOSURE, USE OR DUPLICATION OF THE DOCUMENT OR OF ANY INFORMATION CONTAINED THEREIN FOR OTHER THAN THE SPECIFIC PURPOSE FOR WHICH IT WAS DISCLOSED IS EXPRESSLY PROHIBITED, EXCEPT AS MAY BE OTHERWISE AGREED TO IN WRITING. COPYRIGHT 2003.

A	CORRECTED DIGIT LOCATION ON SECTION B EON#1169	1/28/04	NAP
OR	ORIGINAL RELEASE	1-6-04	NAP
REV.#	CHANGE	DATE	BY

1700 DELAWARE AVE.  
DES MOINES, IA 50317

TITLE	TYPICAL WIRING WR-1400 SERIES INDOOR, LED BAR	DRAWN BY NAP	MODEL: LED BAR
		DATE 1-6-04	DWG. NO. 10-1400-04
		SCALE 1/2"=1'-0"	

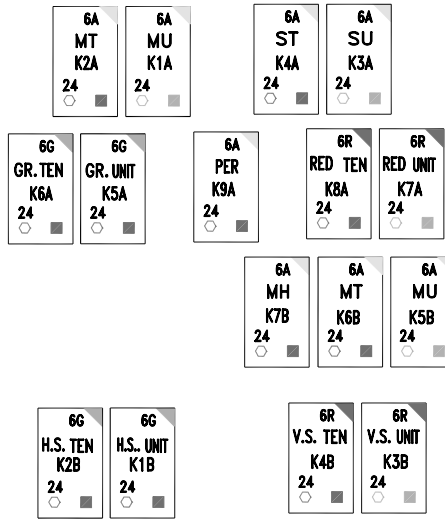
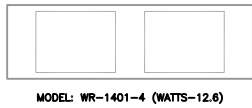
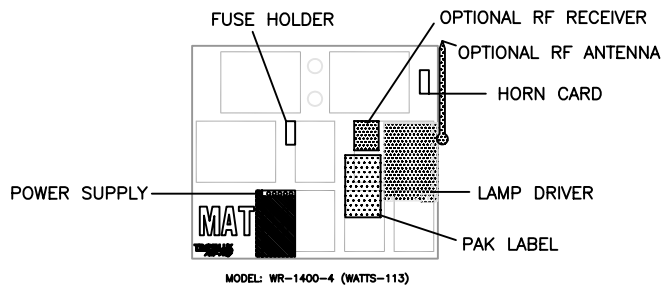

**ASSEMBLY NOTES:**

\*NYOGEL 760G REQUIRED AT LOCATIONS:  
K1A-K10A, K1B-K10B, K23, ON DRIVER LED2022  
ALL CONNECTIONS (HEADERS) ON THE DIGITS.

\*NYOGEL NOT REQUIRED AT LOCATIONS:  
K21, K22, K20, K28, & K24 ON DRIVER LED2022

\*POWER SUPPLY:  
VERIFY POWER SUPPLY IS SWITCHED TO 115VAC  
MEASURE VOLTAGE AT POWER SUPPLY=15 VOLTS DC

\*HIPOT TEST REQUIREMENTS:  
1.5 KILOVOLTS FOR 1 SECOND

\*CONTINUITY CHECK BETWEEN CABINET AND GROUND.

\*POWER CORD AND DATA WILL BE PLACED ON SIDE.

\*WR-1401-4 ATTACH TO SINGLE FACE WR-1400-4 ONLY.

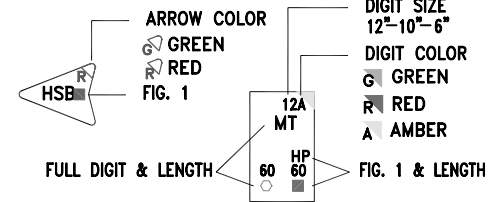
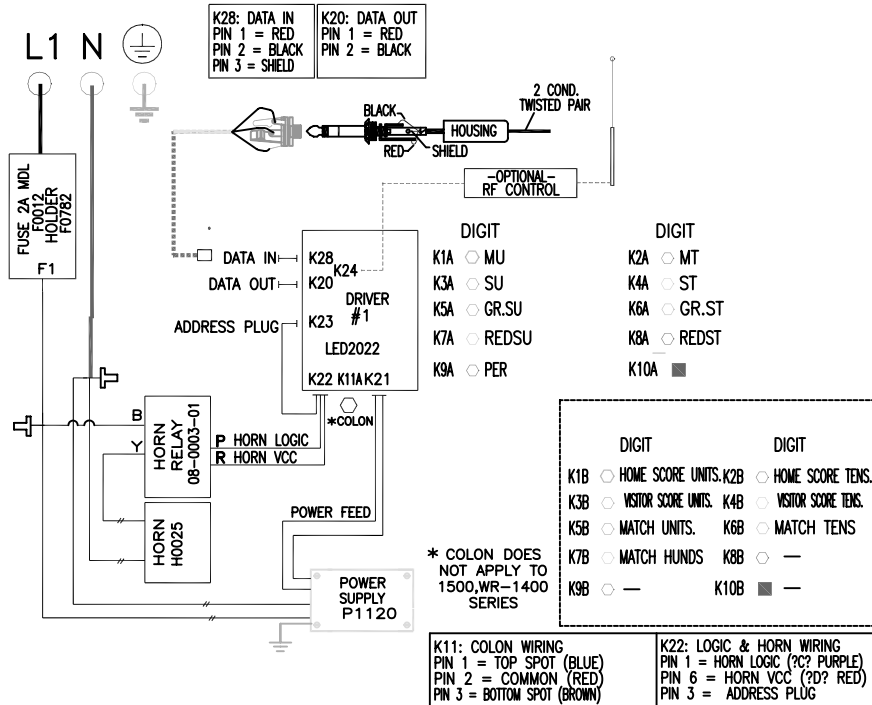

B	ADDED OPTIONAL WR-1401-4 TO WR-1400-4	10-29-07	NAP
A	CORRECTED DIGIT LOCATION ON SECTION B ECN#1169	1/28/04	NAP
OR	ORIGINAL RELEASE	1-6-04	NAP
REV.#	CHANGE	DATE	BY



1700 DELAWARE AVE.  
DES MOINES, IA 50317

THIS DOCUMENT CONTAINS TRANS-LUX PROPRIETARY INFORMATION. ANY DISCLOSURE, USE OR DUPLICATION OF THE DOCUMENT OR OF ANY INFORMATION CONTAINED THEREIN FOR OTHER THAN THE SPECIFIC PURPOSE FOR WHICH IT WAS DISCLOSED IS EXPRESSLY PROHIBITED, EXCEPT AS MAY BE OTHERWISE AGREED TO IN WRITING. COPYRIGHT 2003.

TITLE <b>TYPICAL WIRING WR-1400 SERIES INDOOR, LED BAR</b>	DRAWN BY NAP	A	MODEL: LED BAR
	DATE 1-6-04		DWG. NO. 10-1400-05
	SCALE 1/2"=1'-0"		



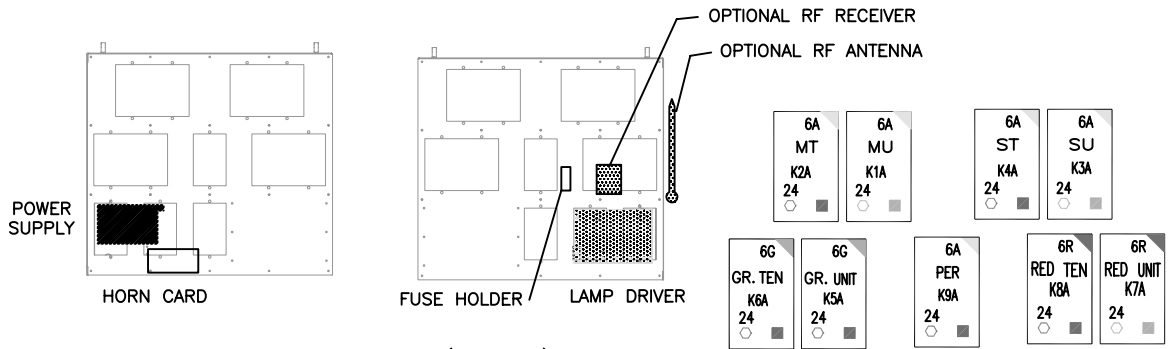

MODEL: WR-1400-2S-4 (WATTS-76)  
PARTS ON BOTH SIDES  
BEHIND MATCH/WEIGHT DIGITS

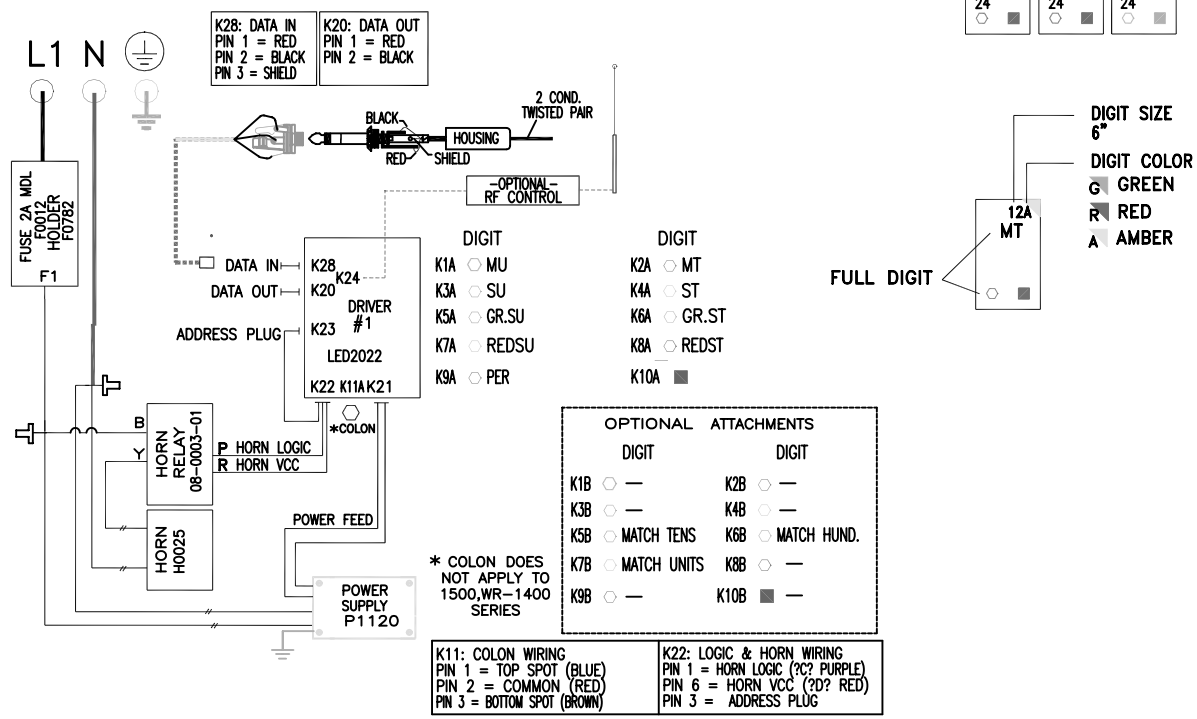

**ASSEMBLY NOTES:**

\*NYOGEL 760G REQUIRED AT LOCATIONS:  
K1A-K10A, K1B-K10B, K23, ON DRIVER LED2022  
ALL CONNECTIONS (HEADERS) ON THE DIGITS.

\*NYOGEL NOT REQUIRED AT LOCATIONS:  
K21, K22, K20, K28, & K24 ON DRIVER LED2022

\*POWER SUPPLY:  
VERIFY POWER SUPPLY IS SWITCHED TO 115VAC  
MEASURE VOLTAGE AT POWER SUPPLY=15 VOLTS DC

\*HIPOT TEST REQUIREMENTS:  
1.5 KILOVOLTS FOR 1 SECOND

\*CONTINUITY CHECK BETWEEN CABINET AND GROUND.

\*ONE HARNESS WILL CONNECT BOTH SIDES TO ONE DRIVER SEE 16-0001-03 FOR CABLES.

\*COMPONENTS PLACED ON BOTH SIDES BEHIND MATCH/WEIGHT DIGITS.

\*POWER CORD AND DATA WILL HAVE TO BE PLACED AT THE SIDE.

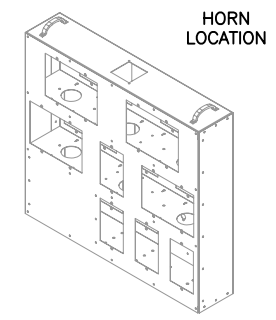

THIS DOCUMENT CONTAINS TRANS-LUX PROPRIETARY INFORMATION. ANY DISCLOSURE, USE OR DUPLICATION OF THE DOCUMENT OR OF ANY INFORMATION CONTAINED THEREIN FOR OTHER THAN THE SPECIFIC PURPOSE FOR WHICH IT WAS DISCLOSED IS EXPRESSLY PROHIBITED, EXCEPT AS MAY BE OTHERWISE AGREED TO IN WRITING. COPYRIGHT 2003.

TITLE <b>TYPICAL WIRING WR-1400-2S-4 INDOOR, LED BAR</b>	DRAWN BY NAP	A	MODEL: LED BAR
	DATE 10-23-08		DWG. NO. 10-1400-07
	SCALE 1/2"=1'-0"		

OR	ORIGINAL RELEASE	10-23-08	NAP
REV.#	CHANGE	DATE	BY

1700 DELAWARE AVE.  
DES MOINES, IA 50317

Parts List			
ITEM	QTY	PART NUMBER	DESCRIPTION
1	1	32-1400-11	CABINET ASSY, WR-1400
2	2	34-1000-86	28" HANGER BRACKET

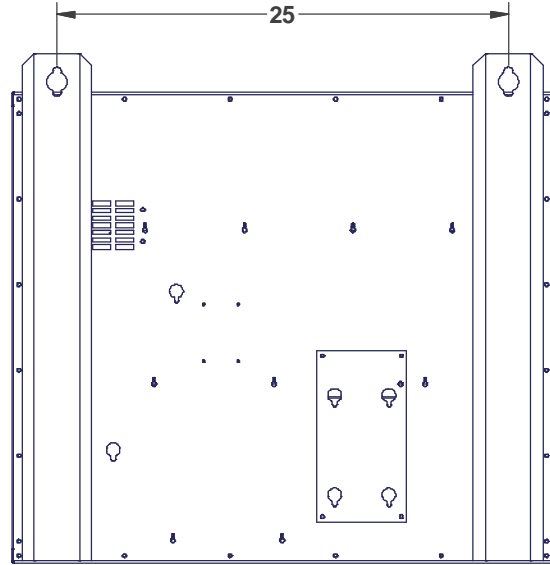
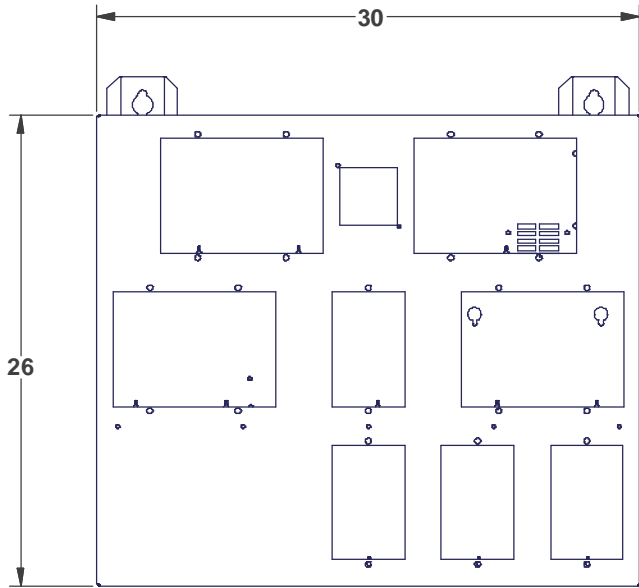

**FRONT VIEW**

**BACK VIEW**

**REF. PRINT 32-1400-11  
FOR CABINET ASSEMBLY**

DRAWN Ldsboecker	1/7/2004	<b>TRANS-LUX</b>	THIS DOCUMENT CONTAINS TRANS-LUX PROPRIETARY INFORMATION. ANY DISCLOSURE, USE OR DUPLICATION OF THE DOCUMENT OR OF ANY INFORMATION CONTAINED THEREIN FOR OTHER THAN THE SPECIFIC PURPOSE FOR WHICH IT WAS DISCLOSED IS EXPRESSLY PROHIBITED, EXCEPT AS MAY BE OTHERWISE AGREED TO IN WRITING.	
CHECKED			TITLE	CABINET ASSY, WR-1400
QA		SIZE	DWG NO	REV
MFG		C	32-1400-13	
APPROVED		SCALE	SHEET 1 OF 1	

4

3

2

1

D

C

B

A

D

C

B

A

RIVET OR SCREW  
SECTIONS TOGETHER

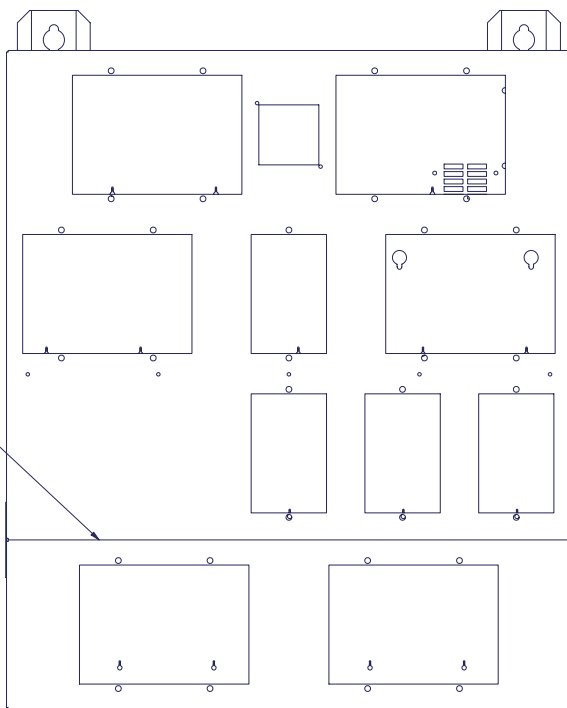

WR-1400

WR-1401

FRONT VIEW

ATTACH WITH 1/4" HARDWARE



SIDE VIEW

DRAWN dstoecker	10/16/2007	 <small>THIS DOCUMENT CONTAINS FAIR-PLAY PROPRIETARY INFORMATION. ANY DISCLOSURE, USE OR DUPLICATION OF THE DOCUMENT OR OF ANY INFORMATION CONTAINED THEREIN FOR OTHER THAN THE SPECIFIC PURPOSE FOR WHICH IT WAS DISCLOSED IS EXPRESSLY PROHIBITED, EXCEPT AS MAY BE OTHERWISE AGREED TO IN WRITING.</small>
CHECKED		
QA		TITLE
MFG		<b>SECTION ASSY, WR-1400 &amp; WR-1401</b>
APPROVED		SIZE C
		DWG NO <b>32-1400-15</b>
		SCALE
		SHEET 1 OF 1

**NOTE:**  
WHEN ORDERING PARTS, FAIR-PLAY PART NUMBER IS REQUIRED.

**LED BAR DIGIT HARNESSSES**

**LED BAR DIGIT ADDRESS PLUG**

CONNECTOR = AMP 640620-8 (C1254)			
PIN = AMP 770904-3 (C1253)			
DOCUMENT REF. 16-0009-01			
ADDRESS PLUG GROUNDED PIN		#22 GAUGE WIRE COLOR	PART#
81	1, 8	RED UL1061 (W0031)	C1384
82	2, 8	BLUE UL1061 (W0026)	C1385
83	1, 2, 8	BLACK UL1061 (W0025)	C1386
84	3, 8	BLUE/BLACK UL1061 (W0130)	C1451
91	1, 5, 8	RED/BLACK UL1007 (W0132)	C1549
B1	1, 5, 6, 8	GRAY UL1061 (W0027)	C1387
B2	2, 5, 6, 8	ORANGE UL1061 (W0029)	C1388
B3	1, 2, 5, 6, 8	YELLOW UL1061 (W0044)	C1389
B4	3, 5, 6, 8	GREEN UL1061 (W0299)	C1390
B5	1, 3, 5, 6, 8	PURPLE UL1061 (W0030)	C1391
B6	2, 3, 5, 6, 8	BROWN UL1061 (W0076)	C1392
B7	1, 2, 3, 5, 6, 8	WHITE UL1061 (W0032)	C1393
B8	4, 5, 6, 8	BLUE/WHITE UL1061 (W0119)	C1394
B9	1, 4, 5, 6, 8	YELLOW/BLACK UL1061 (W0133)	C1535
B10	2, 4, 5, 6, 8	BROWN/WHITE UL1061 (W0121)	C1536
C1	1, 7, 8	ORANGE/BLACK UL1061 (W0131)	C1395
C2	2, 7, 8	PURPLE/WHITE UL1061 (W0135)	C1626
A1	1, 6, 8	ORANGE/WHITE UL1061 (W0120)	C1476
A3	1, 2, 6, 8	WHITE/BLACK UL1061 (W0018)	C1477
85	1, 3, 8	RED/WHITE UL1061 (W0134)	C1604
87	1, 2, 3, 8	PURPLE/WHITE UL1061 (W0135)	C1605
8C	3, 4, 8	PURPLE/BLACK UL1061 (W0136)	C1606

REPLACEMENT INDIVIDUAL PARTS LIST	
DESCRIPTION	F.P. PART#
LED DIGIT (LED2022) DRIVER ASSEMBLY	06-2022-01
LED AMBER	D0273
LED RED	D0272
LED GREEN	D0274
CONNECTOR AMP 640601-2, 2-PIN	C0913
CONNECTOR AMP 640601-3, 3-PIN	C1020
CONNECTOR AMP 103957-1	C1249
CONNECTOR AMP 103957-2	C1248
CONNECTOR AMP 640601-8	C0966
ALT. CONNECTOR AMP 640428-8	
CONNECTOR AMP 640431-9	C1247
STRAIN RELIEF 643067-9	C1270
CONNECTOR 104257-4	C1521
CONNECTOR AMP 640620-8	C1254
CONNECTOR AMP 641522-2	
CONNECTOR AMP 641522-3	
PIN AMP 770904-3, 3-PIN	C1253
POWER SUPPLY, 15VAC@12.5A	P1120

**LED BAR DIGIT FIG. 1 HARNESS**

CONNECTOR = AMP 640601-3 (C1020)  
PIN 1 = GRAY, SEG.  
PIN 2 = RED, COMMON  
PIN 3 = N.C.  
DOCUMENT REF. 16-0013-01

LENGTH	F.P. PART#
12"	C1397
16"	C1416
24"	C1398
36"	C1399
48"	C1400
60"	C1401
72"	C1402
96"	C1403

**DATA CONVERTER INTERFACE HARNESS**

COMPLETE ASSEMBLY = C1396  
CONNECTOR = AMP 104257-4  
DOCUMENT REF. 16-0012-01

PIN#	COLOR	LENGTH
1	RED	6"
2	GREEN	6"
3	BLUE	6"
4	WHITE	6"
5	BLACK	6"

**LED COLON HARNESS**

CONNECTOR = AMP 1-640601-3 (C1020)  
PIN 1 = BLUE (#22 UL1007) TOP SPOT  
PIN 2 = RED (#22 UL007) COMMON  
PIN 3 = BROWN (#22 UL1007) BOTTOM SPOT  
DOCUMENT REF. 16-0014-01

COMPLETE ASSEMBLY	PIN#	COLOR	LENGTH
C1404	1	BLUE	84"
	2	RED	84"
	3	BROWN	72"
C1512	1	BLUE	144"
	2	RED	144"
	3	BROWN	132"

**DIGIT TO DRIVER HARNESS**

CONNECTOR = AMP 640431-9 (C1247)  
STRAIN RELIEF = 643067-9 (C1270)  
DOCUMENT REF. 16-0001-01

**COMPLETE HARNESS**

PIN#	COLOR	BAR SEG.	LED SEG.	LENGTH	F.P. PART#
1	BROWN	A	A	24"	C 1278
2	RED	B	B	36"	C1279
3	ORANGE	C	C	48"	C1280
4	YELLOW	D	D	60"	C1281
5	GREY	E	VLED	72"	C1282
6	BLUE	F	E	84"	C1283
7	PURPLE	G	F	96"	C1284
8	WHITE	FIG. 1	G	108"	C1288
9	BLACK	COMMON	H	120"	C1289
				144"	C1290
				204"	C1456
				216"	C1490
				228"	C1491
				240"	C1505
				300"	C1506

**K10 ADAPTOR HARNESS**

COMPLETE ASSEMBLY = C1417  
CONNECTOR = AMP 640431-9 (C1247)  
CONNECTOR = AMP 641522-2  
CONNECTOR = AMP 641522-3  
STRAIN RELIEF = 643067-9 (C1270)  
DOCUMENT REF. 16-0017-01

CONNECTOR	PIN#	COLOR	F.P.#	F.P.#	LENGTH
AMP 640431-9	5	RED	W0015	W0015	8"
	8	WHITE	W0016	W0016	8"
	9	BLACK	W0008	W0008	4"
AMP 641522-2	1	WHITE	W0016		
	2	BLACK	W0008		
AMP 641522-3	1	BLACK	W0008		
	2	RED	W0015		
	3	N.C.			

**LED BAR WRESTLING SCOREBOARD DATA CHART**

	SCBD TYPE	WIRELESS OPTIONAL	SIZE		EST. WT. (LBS.)	POWER			CTRL	HANGER DIM. REFERENCE DRAWING
			"A" LENGTH	"B" HEIGHT		CIRCUITS REQ'D.	CIRCUIT #1 (WATTS)	TOTAL WATTS		
<b>WR-1400-4</b>	02	X	2'-6"	2'-2"	15	1	38	38	MP-70	32-1400-13
<b>WR-1401-1</b>			2'-6"	9"	10					ATTACHES TO BOTTOM OF WR-1400-4
<b>WR-1400-2S-4</b>	02	X	2'-6"	2'-2"	30	1	76	76	MP-70	
<b>WR-1400-3S-4</b>	02	X	2'-6"	2'-2"	45	1	114	114	MP-70	32-1400-12

MODEL #:      -4 = LED BAR DIGIT

LAMP TYPE: LED

\* POWER IS 120 VAC, 60 Hz, 2 WIRE.

\* CONTROL CABLE TYPICAL=C0550, 1-PAIR, 22 GAUGE ((1) PER SCOREBOARD)

# *Fair-Play*

**A TRANS-LUX® COMPANY**

**TRANS-LUX MIDWEST CORPORATION  
d.b.a. Fair-Play Scoreboards**

## **LIMITED SCOREBOARD WARRANTY**

Fair-Play provides a limited five-year warranty when its permanently mounted scoreboards and scoreboard controllers are operated and maintained according to the owner's instructions furnished with the equipment. Such limited warranty is two years for portable scoreboards. This warranty covers all electronic components, including LEDs, for five or two years as applicable from the date of invoice that prove to be defective in material or workmanship. Our #161 and #655-type indoor lamps are warranted on a ten-year factory exchange basis from the date of invoice.

Warranted for one year are mechanical control panel switches, connectors, horns and visual goal indicators. Wireless control components are warranted for two years. Wireless control devices even if not defective may not function reliably in certain environments or otherwise due to outside causes beyond Seller's control, including but not limited to cell phones or portable computers. In the event it is determined a wireless device during the ninety (90) day period following shipment does not function in accordance with its specification without repeated errors or is otherwise consistently unreliable, and Seller determines repair or replacement thereof is not likely to improve performance, at Purchaser's request, upon return to Seller postage prepaid in like new condition within such time period, Seller's sole obligation shall be to refund the entire purchase price of such device. Thereafter Seller's sole obligation shall be to repair or replace, other non-wireless defective components for the balance of the warranty period without responsibility or liability for claims for unreliable performance not due to defects. Batteries, battery packs and battery recharging equipment are warranted for thirty (30) days, except for defects arising from misuse, abuse, negligence or other exclusions set forth below. In no event will Fair-Play have any obligation for any damage caused by defective batteries, battery packs and battery recharging equipment. Also warranted for 30 days are outdoor portable scoreboard carts.

Fair-Play's sole obligation during the applicable warranty period is to repair or replace any defective items. Defective assemblies or components are to be returned postage prepaid to Fair-Play's service center, after obtaining a return authorization number, for repair or replacement at no cost to the owner during the applicable warranty period. Replacement parts may be either new or like-new. Return shipping costs after repair will be paid by Seller except for overnight, express or special shipping costs which shall be paid by Purchaser.

Excluded from this warranty are fuses, major components provided by other manufacturers including, but not limited to, computers, rotating signs, power distribution panels, disconnect switches and components of rear-illuminated or lighted signs. The other manufacturer's warranty will apply to such components. Also excluded from this warranty are electronic signs or message centers and related controls. These items are covered by their own specific warranty.

**THIS WARRANTY IS IN LIEU OF ALL OTHER WARRANTIES OF SELLER, EXPRESS OR IMPLIED, AND, EXCEPT TO THE EXTENT HEREIN PROVIDED, SELLER DOES NOT MAKE ANY WARRANTY WHATSOEVER INCLUDING, WITHOUT LIMITATION, ANY WARRANTY OF MERCHANTABILITY OR FITNESS FOR ANY PARTICULAR USE OR PURPOSE.**

Fair-Play shall not be liable for any incidental, special or consequential damages nor any other loss that may arise in connection with its warranted equipment or any claims under this warranty. (Individual states may have limitations on the length of implied warranties.)

This warranty does not cover shipping damages or problems which result from improper installation of your equipment. (Promptly inspect shipment for visible or concealed damages and report immediately to the delivering carrier.)

Under no circumstances shall this warranty apply if the warranted products have been subject to abuse, misuse, neglect, sabotage, acts of terrorists, negligence, accident, or any casualties or abnormal conditions, including without limitation fire, civil disorders, war, flood, lightning or acts of God. Nor does this warranty cover labor or damage resulting from, or problems caused by, any repair, alteration, modification, or adjustment of the warranted scoreboard(s) or components not performed by Fair-Play.

This warranty extends only to the original purchaser of the warranted products, and is not transferable. For information on extended warranties contact your Fair-Play dealer. In the event authorized Fair-Play dealers make extensions to or provide additional service for Fair-Play products, Fair-Play assumes no liability therefore other than the specific warranty set forth above in this Limited Warranty.

Fair-Play Scoreboards - A Division of Trans-Lux Midwest Corporation  
For Service contact: Trans-Lux Repair Center, 110 Richards Avenue, Norwalk, CT 06854  
Telephone: 800-462-2716 Fax: (203) 831-8827  
Internet Address - [www.fair-play.com](http://www.fair-play.com)

Effective 0518-04 © 2004, Fair-Play Scoreboards, All rights reserved.