

REVISION	DATE	INITIALS	DESCRIPTION
C	09/13/2007	SJD	ADDED 08-2042-01
B	4/11/2007	SW	DEFINE TEST CARD AS "DUT"; CORRECTED STEP 9.1.7; INSERTED A NEW STEP AT 10.5
A	3/23/2007	SW	REFORMATTED & UPDATED
OR	11/29/2004		ORIGINAL DOCUMENT RELEASE

TEST PROCEDURE FOR 08-1042-01 AND 08-1042-02 AND 08-2042-01 PCA'S

THIS DOCUMENT CONTAINS TRANS-LUX PROPRIETARY INFORMATION. ANY DISCLOSURE, USE, OR DUPLICATION OF THE DOCUMENT OR OF ANY INFORMATION CONTAINED THEREIN FOR OTHER THAN THE SPECIFIC PURPOSE FOR WHICH IT WAS DISCLOSED IS EXPRESSLY PROHIBITED, EXCEPT AS MAY BE OTHERWISE AGREED TO IN WRITING. COPYRIGHT 2003.

1.0 Objective

This document specifies the inspection procedure for an assembled 26-1042-01 PCB.

2.0 Definitions

- **DUT** – device under test: either the 08-1042-01, 08-1042-02, PCA 08-2042-01 (UXC)
- **ESD** – electro-static discharge.
- **LCD** – liquid-crystal display.
- **PC** – personal computer equipped with both USB and serial data communication ports.
- **PCA** – printed circuit assembly
- **PCB** – printed circuit board
- **Test Jig** – the UXC PCA test apparatus (PC, power supply, interface harness, etc.)
- **UXC** – the abbreviated product name assigned to the Trans-Lux universal control unit.

3.0 Applicable Documents

98-1042-04, UXC firmware programming procedure – NIOS1 method.
 98-1042-05, UXC firmware programming procedure – NIOS2 method.
 26-1042-01, PCB schematic.
 08-1042-01, standard UXC control PCA assembly drawing
 08-1042-02_DOC, UXC control PCA assembly drawing – Color Captivue conversion
 08-2042-01, PCA UXC control PCA assembly drawing

4.0 Equipment and Materials Required (in order of appearance)

- A visual magnifier with 10x to 60x magnification range.
- A volt/ohm meter.
- A standard AC power outlet strip with built-in ON/OFF switch.
- A Radio Shack® 18/24 VAC power adapter, provided by Trans-Lux.
- A +12 VDC power supply, p/n P1254, with power leads, provided by Trans-Lux..
- A DB-9 to DB-9 straight-through cable, p/n 06-0051-01, provided by Trans-Lux.
- Two UXC assemblies, one p/n 24-0024-09 and one p/n 24-0024-11, that are in known good working order. These are the test jig UXC assemblies, provided by Trans-Lux.
- A PC with these Altera Co. software applications installed and running:
 - Quartus II version 6.0, with NIOS II

- SOPC Builder 6.0 (also called NIOS II Command Shell)
- A UXC to UXC test harness, p/n 98-0075-01, provided by Trans-Lux.
- A six-line (48-row x 16-column), amber LED test display, provided by Trans-Lux.

5.0 Equipment Safety

Please observe ESD safety precautions. All testing shall be conducted on a properly grounded workbench with an anti-static, non-conductive surface.

6.0 Assembly Workmanship Inspection

Visually inspect each DUT for compliance to the materials list and assembly documentation using appropriate magnification as needed. 10x magnification is the minimum preferred level. Soldering workmanship and component placements shall be inspected in accordance with IPC-610 Class 2 requirements. Particular attention should be paid to the following:

- 6.1 PCB defects: open or short-circuited conductive paths or material delamination.
- 6.2 PCA cleanliness: flux or other chemical residue, solder or other debris.
- 6.3 Correct component placements and polarity orientation as applicable: missing, loose, or misaligned parts, bent or lifted component pins, frayed wires, wrong devices or values populated.
- 6.4 Soldering flow and proper termination wetting: excessive or inadequate solder amount, solder bridges, pillowed or cold joints.
- 6.5 Labels have been applied in the specified locations per Trans-Lux assembly documentation.
- 6.6 Conformal coat application: overspray on connectors, headers, test points & other contact locations.

7.0 Test for Short-Circuit From Voltage Sources to Ground

- 7.1 Set the volt/ohm meter to measure resistance. Connect the common lead to DUT ground reference pin GND1. Touch the positive lead to TP1 (VCC). The resistance reading should be around 56 ohms.
- 7.2 Now touch the positive lead to TP2 (3.3V). The resistance reading here should be approximately 74 ohms.
- 7.3 Next, touch the positive lead to TP4 (60Hz). This resistance reading should be a very high reading (∞ infinite).
- 7.4 Finally, touch the positive lead to TP22 (Vunreg). This resistance should read somewhere between 2 to 6 Meg-ohms.

Note: widely divergent readings at any of these test points should make you suspect an electrical problem with that DUT. In this case, tag the card with the fault symptom and set it aside for problem analysis.

8.0 UXC firmware programming

- 8.1 If you are testing an 08-1042-01 PCA, complete the firmware programming procedure as outlined in document 98-1042-04.
- 8.2 If you are testing an 08-1042-02 PCA, complete the firmware programming procedure as outlined in document 98-1042-05.

9.0 Functional Test Setup

9.1 Referencing illustration 1 on pg. 4, interconnect the test hardware as follows:

- 9.1.1 Plug the AC power outlet strip (switched off) to a standard AC wall outlet.
- 9.1.2 Plug the 18/24 VAC power adapter into any available power strip outlet, and connect the adapter cable leads to the DUT J18 screw terminals (polarity is not important).
- 9.1.3 Plug the +12 VDC power supply power cord into any available power strip outlet, and connect the +V and -V power leads to the test jig UXC and the DUT J17 screw terminals. **Polarity IS important in this instance, so make sure the orange +V lead is connected to pin 1 and the gray -V lead is connected to pin 2.**
- 9.1.4 Connect one end of the DB-9 to DB-9 straight-through cable, p/n 06-0051-01, to the bottom DB-9 connector of the test jig UXC J10 header, and the opposite end the PC serial communication port.
- 9.1.5 Connect the UXC to UXC test harness, p/n 98-0075-01, between the test jig UXC and the DUT. Each cable connector is labeled with its port connection assignment. The ports are arranged on the UXC cards as follows:
 - 9.1.5.1 Port 1 is the bottom DB-9 connector of the J2 header.
 - 9.1.5.2 Port 2 is the top DB-9 connection of the J2 header.
 - 9.1.5.3 Port 3 is the bottom DB-9 connector of the J5 header.
 - 9.1.5.4 Port 4 is the top DB-9 connection of the J5 header.
 - 9.1.5.5 Port 5 connects to the 3-pin J9 header, to the left of crystal Y1.
 - 9.1.5.6 Port 7 is the top DB-9 connection of the J10 header.

ILLUSTRATION 1

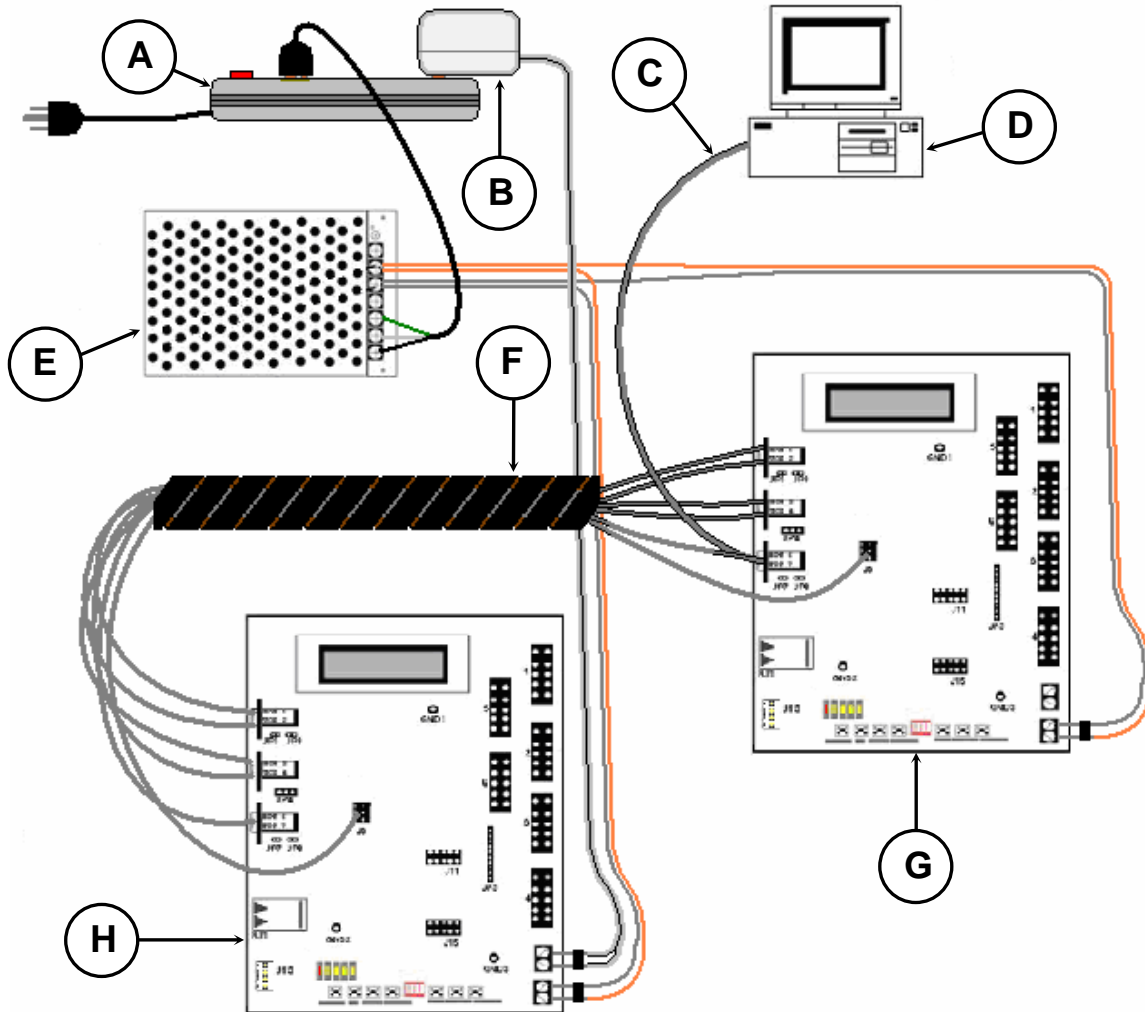

- A. AC power outlet strip
- B. Radio Shack® 18/24 VAC power adapter
- C. DB-9 to DB-9 straight-through cable, p/n 06-0051-01
- D. PC
- E. +12 VDC power supply, p/n P1254, with power leads
- F. UXC to UXC test harness, p/n 98-0075-01
- G. Test jig UXC (either 24-0024-09 or 24-0024-11, depending on test application) **
- H. DUT (either 08-1042-01, 08-1042-02, or 08-2042-01 depending on test application) **

** **IMPORTANT:** The test jig UXC and the DUT must BOTH have the same firmware version installed for the automated test routine to run properly. Consult Trans-Lux for information on the most current firmware releases.

9.1.6 Set the DUT SW1 switch in **Diagnostic Mode**, as shown below (all switches closed).

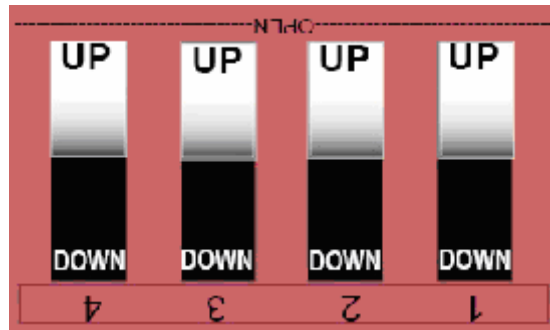

9.1.7 Set the test jig UXC SW1 switch in **Test Jig Mode**, as shown below (switches 1 and 3 open, switches 2 and 4 closed).

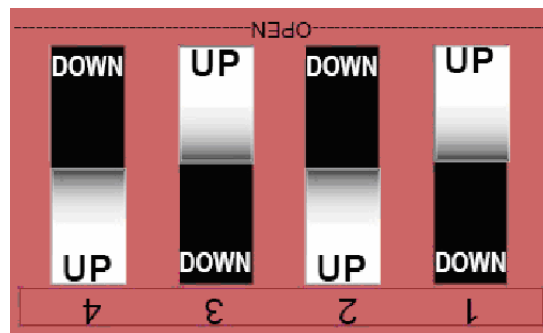

10.0 Procedure 1: Automated Serial Port Test

10.1 Open the SOPC Builder program (a.k.a. Nios II Command Shell) by double clicking the PC desktop icon shown below.



10.2 The SOPC Builder window opens and a message appears, similar to the one below.

```

c:\ SOPC Builder 6.0
-----
Welcome To Altera SOPC Builder
Version 6.0, Built Mon Apr 24 15:26:45 PDT 2006
-----

Welcome to the Nios II Embedded Design Suite
Version 6.0, Built Fri Apr 21 04:12:54 PDT 2006

Example designs can be found in
  /cygdrive/c/altera/kits/nios2_60/examples

(You may add a startup script: c:/altera/kits/nios2_60/user.bashrc)
/cygdrive/c/altera/kits/nios2_60/examples
ISOPC Builder1$ nr -t -r_

```

- 10.3 Type the command **nr -t -r** (lower case typeset) as shown in the message window graphic of step 10.2, and press **ENTER** to engage “terminal mode”.
- 10.4 Switch on the AC power strip.
Note: when power is applied, you should see a green light turn on at the bottom right-hand side of the +12 VDC power supply. You should also see activity on the LED’s above the “ESCAPE” button, and also on the LCD, of both the DUT and the test jig UXC.
- 10.5 Confirm that the word “DIAGNOSTICS” appears on the DUT LCD screen, and “TEST JIG MODE” appears on the test jig UXC LCD screen. If something other appears, check the switch settings for each PCA in steps 9.1.6 and 9.1.7.
- 10.6 The SOPC Builder will automatically communicate with the test jig UXC and present a list of command options in the application window as shown below.

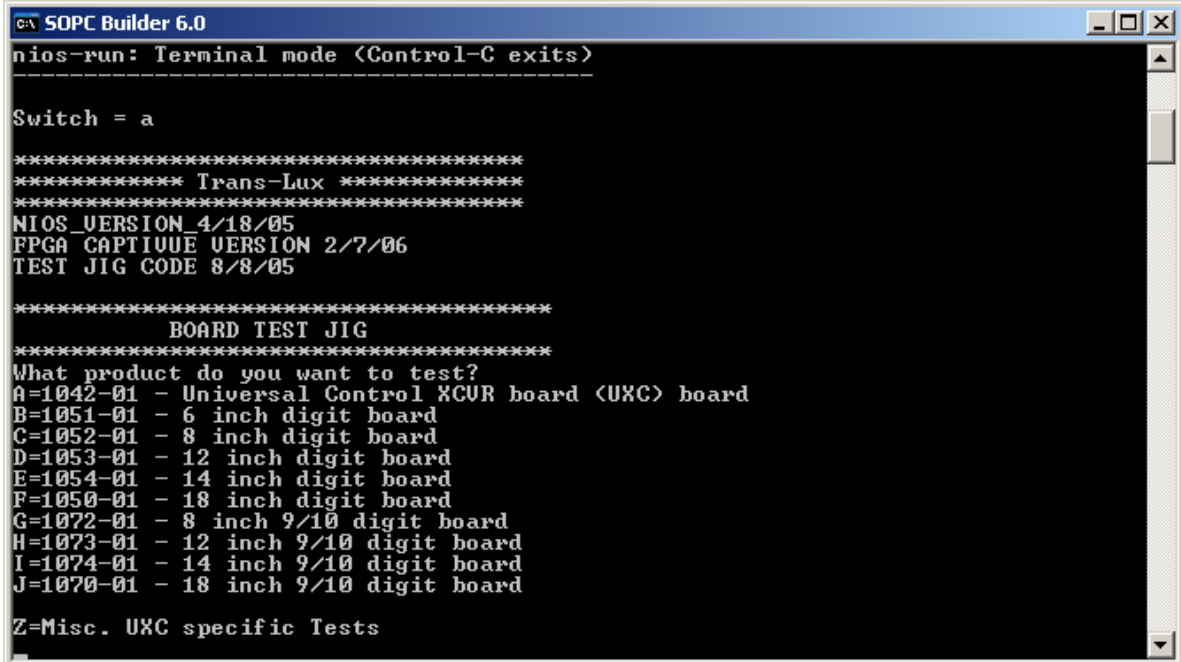

```

C:\> SOPC Builder 6.0
nios-run: Terminal mode <Control-C exits>
-----
Switch = a

*****
***** Trans-Lux *****
*****
NIOS_VERSION_4/18/05
FPGA_CAPTURE_VERSION_2/7/06
TEST JIG CODE 8/8/05

*****
***** BOARD TEST JIG *****
*****
What product do you want to test?
A=1042-01 - Universal Control XCUR board (UXC) board
B=1051-01 - 6 inch digit board
C=1052-01 - 8 inch digit board
D=1053-01 - 12 inch digit board
E=1054-01 - 14 inch digit board
F=1050-01 - 18 inch digit board
G=1072-01 - 8 inch 9/10 digit board
H=1073-01 - 12 inch 9/10 digit board
I=1074-01 - 14 inch 9/10 digit board
J=1070-01 - 18 inch 9/10 digit board

Z=Misc. UXC specific Tests

```

- 10.7 Press the ‘A’ key on your PC keyboard to select command option A. Additional instructions and commands will appear in the application window, shown below. The cable interface connections have already been made.

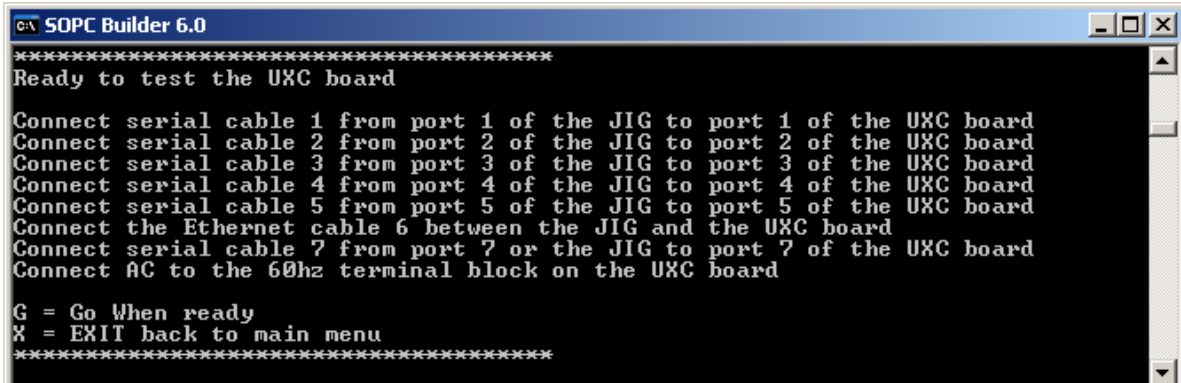

```

C:\> SOPC Builder 6.0
*****
Ready to test the UXC board

Connect serial cable 1 from port 1 of the JIG to port 1 of the UXC board
Connect serial cable 2 from port 2 of the JIG to port 2 of the UXC board
Connect serial cable 3 from port 3 of the JIG to port 3 of the UXC board
Connect serial cable 4 from port 4 of the JIG to port 4 of the UXC board
Connect serial cable 5 from port 5 of the JIG to port 5 of the UXC board
Connect the Ethernet cable 6 between the JIG and the UXC board
Connect serial cable 7 from port 7 of the JIG to port 7 of the UXC board
Connect AC to the 60hz terminal block on the UXC board

G = Go When ready
X = EXIT back to main menu
*****

```

- 10.8 Press the 'G' key on your PC keyboard to engage the automated serial port test. Pass / fail indications will be posted in the application window for each test as it is completed. The results of a successful test are shown below.

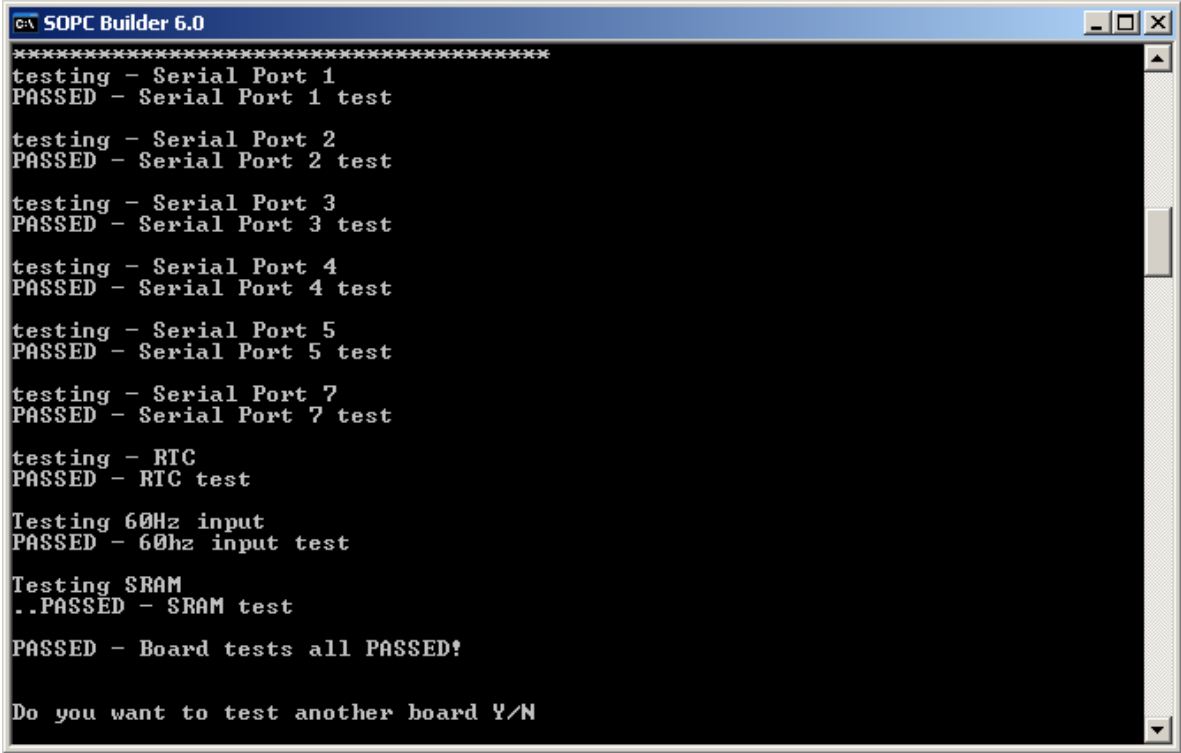

```
C:\ SOPC Builder 6.0
*****
testing - Serial Port 1
PASSED - Serial Port 1 test
testing - Serial Port 2
PASSED - Serial Port 2 test
testing - Serial Port 3
PASSED - Serial Port 3 test
testing - Serial Port 4
PASSED - Serial Port 4 test
testing - Serial Port 5
PASSED - Serial Port 5 test
testing - Serial Port 7
PASSED - Serial Port 7 test
testing - RTC
PASSED - RTC test
Testing 60Hz input
PASSED - 60hz input test
Testing SRAM
..PASSED - SRAM test
PASSED - Board tests all PASSED!
Do you want to test another board Y/N
```

The following screen shows test results from a card that has a problem with serial ports 3 & 4, and the AC voltage input at J18.

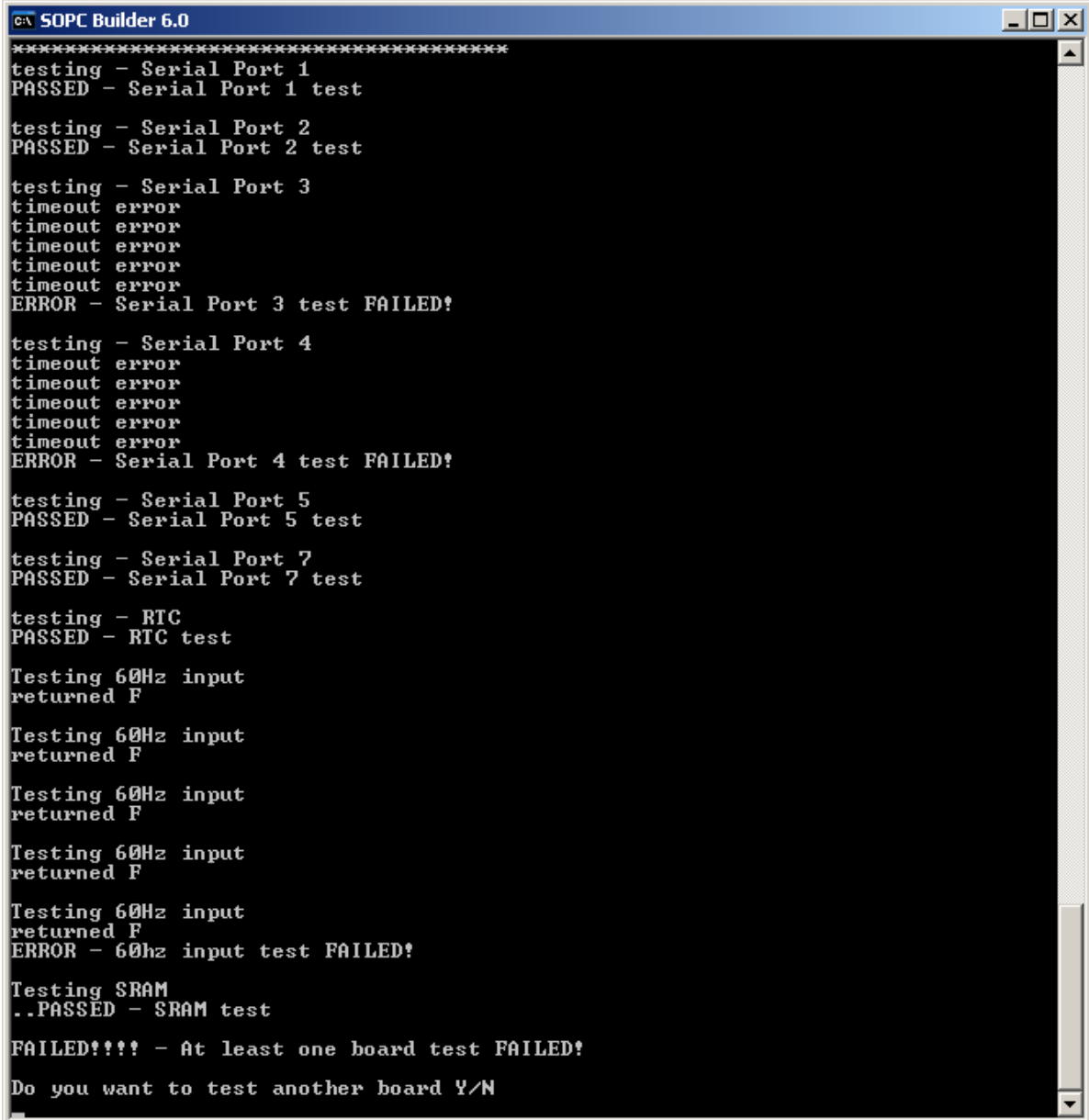

```
C:\ Sopc Builder 6.0
*****
testing - Serial Port 1
PASSED - Serial Port 1 test

testing - Serial Port 2
PASSED - Serial Port 2 test

testing - Serial Port 3
timeout error
timeout error
timeout error
timeout error
timeout error
ERROR - Serial Port 3 test FAILED!

testing - Serial Port 4
timeout error
timeout error
timeout error
timeout error
timeout error
ERROR - Serial Port 4 test FAILED!

testing - Serial Port 5
PASSED - Serial Port 5 test

testing - Serial Port 7
PASSED - Serial Port 7 test

testing - RTC
PASSED - RTC test

Testing 60Hz input
returned F

Testing 60Hz input
returned F

Testing 60Hz input
returned F

Testing 60Hz input
returned F

Testing 60Hz input
returned F
ERROR - 60hz input test FAILED!

Testing SRAM
..PASSED - SRAM test

FAILED!!! - At least one board test FAILED!

Do you want to test another board Y/N
```

In this instance, the cable connections to serial ports 3 and 4 were reversed, and one of the J18 screw terminals had conformal coat over spray sufficient enough to impair electrical connectivity. These are common, quickly resolved issues. Fail indications will also occur if the SW1 switches are not set as specified in steps 9.1.6 and 9.1.7, or if either SW1 or SW4 (CPU reset) are defective. If a fail condition persists after all connections / switch settings have been validated as correct, set the DUT aside for problem analysis. Otherwise proceed on.

11.0 Procedure 2: Set the LCD Contrast Voltage.

- 11.1 Set the volt/ohm meter to measure DC millivolts. Connect the common lead to DUT ground reference pin GND1. Touch the positive lead to pin 3 of the DUT J6 LCD interconnect header. Using a small, flat-tip screwdriver, rotate the R1 screw adjustment as necessary for a comfortable background vs. text viewing contrast (typically between 50 and 500 millivolts DC on the meter).



```
Trans-Lux 111305
DIAGNOSTICS
```

If you are unable to clearly read text on the LCD screen similar to that shown in the image above, tag the DUT with the fault symptom and set it aside for problem analysis. Problems such as horizontal or vertical lines (either dark or blank) are often corrected by simply installing a new LCD module (power off during replacement).

- 11.2 Switch off the AC power strip and disconnect the UXC to UXC test harness cables from the DUT.

12.0 Procedure 3: Output Port Test

- 12.1 Referencing illustration 2 on page 10, connect the six-row, amber LED test display ribbon cables into their assigned DUT output ports, row 1 cable to row 1 connector J1, row 2 cable to row 2 connector J4, etc.
- 12.2 If not already done, plug the test display power cable into any available power strip outlet.
- 12.3 Switch on the AC power strip.
- 12.4 The DUT will initialize in the **Diagnostic Mode**. Make sure at the first three letters of the English alphabet are displayed on each row of the test display, as shown in illustration 2. If any anomalous behavior is observed on the display, tag the DUT with the fault symptom and set it aside for problem analysis. Otherwise, the DUT passes and the functional test is finished.
- 12.5 Switch off the AC power strip and disconnect the ribbon cables from the DUT output ports.
- 12.6 Initial and date a functional test label and apply it to the DUT.

ILLUSTRATION 2

